



DELHI PUBLIC SCHOOL ALIGARH
CLASS-X
HOLIDAY HOME WORK-2023-24

Dear students,

This summer vacation let the waves hit your feel, and the sand be your seal. Summer vacation is always meant for fun, frolic and rejuvenation. However, it also means enhancing our skills, becoming more polished and productive at the same time. To ensure we are keeping ourselves creative and innovative, and not just intelligent, our team of teachers have created some mind-blowing activities for you to enjoy and learn from!

Please read through the instructions carefully before completing the tasks.

Wishing you a vacation full of tanning, memories and creative vigor!
Happy holidays!

SUBJECT-ENGLISH

1. VISUALISE AND DRAW (ART INTEGRATION PROJECT)

Read the text carefully. What do you imagine this scene might look like? Draw an attractive image on A4 size pastel sheet to match the text. **(ANY 1)**

- A. I stood at the bottom of an impossibly tall staircase. It sparkled and shone, golden in the bright sunlight, as it curled up and up into the clouds. There was no way to know what might be up there, the clouds thick and fluffy, blocking the view of the top. I took a deep breath and stepped onto the first stair.
- B. It was quiet and still in the woods. No birds singing in the trees, no sounds of footsteps through the dirt. They were there though, hiding. Birds and animals of all shapes and sizes, peeking through the branches to see the bright shining object that had just fallen into the clearing.
- C. The pirate ship sailed along the ocean towards us, black flag flying high to let everyone know just who was on board. Our ship was much smaller and only had two cannons compared to their six. We were in trouble!

2. SYMBOLISM

A Symbol is a shape, mark, character or idea which represents something else. It's a 'shorthand' to bigger concepts and more complex ideas.

SYMBOLISE YOURSELF

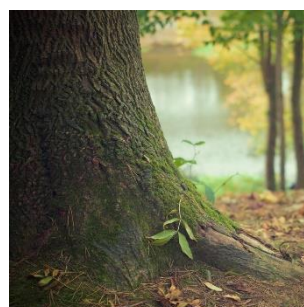
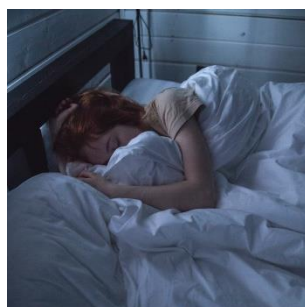
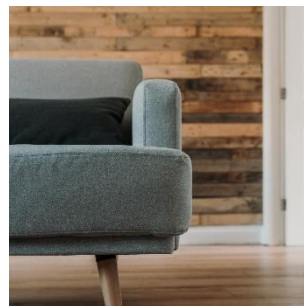

Choose an object or an action to represent **you** – it can show an aspect of your personality, something you enjoy doing or just your mood today. Write a paragraph in 150 words to explain the symbol and how does it represent you. You may choose from the pictures or think of one that's individual to you!

3. SPEECH SCANNING

You have recently read the Inaugural speech given by Nelson Mandela in Pretoria. Here are the links for world's most famous speeches. Listen to them carefully two to three times. Prepare a write up in about 400- 500 words expressing your views on the speech mentioning the occasion, purpose, difference in delivery style, particular phrase or sentence you liked, use of figurative language etc and submit it in the project file. You have to present the same in front of the whole classes (without using the written script) in the first week of July. The session will be considered as ASL and recorded. Prepare yourself thoroughly for the cross questioning by students and examiner.

LINKS:

https://www.youtube.com/watch?v=pJiXu4q_VU

https://www.youtube.com/watch?v=fHi_xvrvUm8

<https://www.youtube.com/watch?v=bC4kQ2-kHZE>

SUBMIT ALL YOUR WORK IN A PROJECT FILE.

SUBJECT-HINDI

निर्देशानुसार समस्त गृहकार्य पूर्ण करें।

प्रश्न 1—पाठ्यक्रम संबंधित फिल्म दर्शन—

दृश्य श्रव्य गतिविधि—

क—भारत चीन युद्ध 1962 पर आधारित 'हकीकत' फिल्म देखिए तथा कविता 'कर चले हम फिदा' के आधार पर 'अपने देश के प्रति कर्तव्य और उसकी सुरक्षा' विषय पर अपनी भूमिका सुनिश्चित करते हुए 150 शब्दों में अपने विचार लिखिए। फिल्म का जो दृश्य आपको सबसे अच्छा लगा, पाँच वाक्यों में उसका कारण लिखिए।

ख—1—राज कपूर और वहीदा रहमान की फिल्म 'तीसरी कसम' देखिए तथा पाठ 'तीसरी कसम के शिल्पकार: शैलेंद्र' के संदर्भ में बताइए कि क्या प्रत्येक फिल्मकार को दर्शकों के विचारों को परिष्कृत करने वाली फिल्म बनानी चाहिए? हाँ और ना का तर्क सहित 100 शब्दों में उत्तर दीजिए।

2—'वर्तमान परिपेक्ष्य में फिल्मकारों की भूमिका' पर 150 शब्दों में अनुच्छेद लिखिए।

3—ग्रीष्मावकाश में कोई ऐसी फिल्म देखिए जो 'ततारा वामीरो कथा' के उद्देश्य पर आधारित हो फिल्म, के नायक—नायिका का नाम देते हुए 100 शब्दों में स्पष्ट कीजिए कि क्या वास्तव में फिल्में वर्तमान पीढ़ी के विचारों में परिवर्तन और समाज के विकास में सहायक होती हैं? सर्वाधिक प्रभावित करने वाले दृश्य का चित्र भी लगाइए।

4—स्मरण गतिविधि—

क—व्याकरण की पुस्तक में दिए गए पाठों पर आधारित मुहावरे 'अंतर्कक्षीय मुहावरा प्रतियोगिता' हेतु याद कीजिए।

ख—'कबीर की साखियाँ' याद करके सस्वर वाचन करते हुए अपना वीडियो बनाइए तथा दी गई मेल आईडी पर भेजिए। (रोल नंबर 1—20 के छात्र)

ग— 'कर चले हम फिदा' कविता का सस्वर वाचन करते हुए वीडियो बनाइए। (रोल नंबर 21 से 40) मेल आईडी पर भेजिए। आईडी कक्षा 10 अ के लिए — tempnibha@gmail.com . आई डी कक्षा 10 ब के लिए — kbrsharma20@gmail.com

लेखन गतिविधि—

5—अपने दादा—दादी, नाना—नानी पड़ोसियों या रिश्तेदारों के, बुजुर्गों के प्रति व्यवहार का अवलोकन करें, उनके साथ बातचीत करते हुए एक फोटो खींचकर परियोजना फाइल में लगाकर, 'हरिहर काका' पाठ की सार्थकता को 100 शब्दों में स्पष्ट करें।

6—ग्रीष्मावकाश में अपने शैक्षिक—भ्रमण अथवा कहीं की भी अपनी यात्रा के किन्हीं पाँच दिनों के अनुभवों को डायरी लेखन कला के आधार पर 150 शब्दों में लिखें, प्रतिदिन का एक फोटो भी लगाएं।

7—श्रवण गतिविधि—नीलेश मिश्रा की एफएम पर परिश्रम, सहयोग, ईमानदारी, आत्मविश्वास, स्वावलंबन आदि नैतिक मूल्यों पर आधारित कहानियाँ सुनकर किन्हीं पाँच कहानियों को 150 शब्दों में लिखिए। कहानी वाचन की कला को समझिए।

8—ग्रीष्मकालीन अवकाश के दौरान पशु— पक्षी व प्रकृति संरक्षण में अपना योगदान सुनिश्चित करते हुए अपने चार फोटो लगाइए। विषय पर 150 शब्दों में अपने विचार लिखिए।

नोट— समस्त लेखन कार्य परियोजना पुस्तिका में सुंदर लेख व शुद्ध वर्तनी में करना है।

SUBJECT-URDU

Select any one contemporary topic of Social or Educational importance. Collect pictures related to that topic from Urdu/ English/Hindi newspaper and from Urdu Magazine also (Mahnama Umang, Bachcho ki Duniya- latest issue) and prepare a **Scrap Book**. And also prepare a report on the same topic. (500 words limit)

OR

Prepare a Chart Paper which will be decorated and write ISM (Noun) aur uski qismien, Sifat (Adjective) aur uski qismien & Fael (Verb) aur uski qismien.

SUBJECT-SANSKRIT

- 1- कोई भी दो पत्र छाँटकर मंजूषा की सहायता से रिक्त स्थान भरकर पुनः लिखिए।
- 2- ग्रीष्मावकाश में जहाँ भी भ्रमण हेतु जाएँ वहाँ से संबंधित या समाचार पत्र से कोई भी दो चित्र छाँटकर, उस पर पाँच संस्कृत में लिखिए।
- 3- नास्तित्यागसमं सुखम् व रमणीया हि सृष्टिरेषा पाठ से दस दस कठिन शब्दों को छाँटकर उसका अर्थ लिखिए व प्रश्न निर्माण भी कीजिए।
- 4- किसी एक संस्कृत कवि और एक लेखक का चित्र बनाकर पर आधारित पाँच पाँच सरल वाक्य संस्कृत में लिखिए।

SUBJECT-MATHEMATICS

Activity 1: Math Podcast or Video

1. Create a podcast episode or a video on a specific topic from class X Mathematics syllabus.
2. Present the topic in an engaging and interactive manner, explaining concepts, providing examples and solving problems.
3. Incorporate visuals, animations or props to enhance the presentation.
4. Mail your presentation to the following id's:
XA : seema@dpsaligarh.org
XB : binodsharma@dpsaligarh.org

Activity 2: Data Analysis Project

1. Collect data on a topic of interest (e.g., sports, social media usage, favourite movies).
2. Analyse the data using appropriate statistical measures.
3. Draw conclusions and present your findings in the form of a report or a presentation.

Activity 3: Math in Nature

1. Go on a nature expedition and capture photographs or sketches of patterns, shapes and structures that demonstrate mathematical principles.
2. Create a photo album or a collection of drawings, labeling each image with the relevant mathematical concept it represents.
3. Write a reflection on the prevalence of mathematics in nature and its significance.

Activity 4: Math Puzzle Collection

1. Create a collection of three math riddles or puzzles to challenge your peers or family members.
2. Write down the riddles or puzzles along with their solutions, making sure to explain the mathematical concepts or techniques involved.

Check your Progress:

Do first two exercises of the six chapters covered in class from NCERT Exemplar in Homework Notebook.

Note: Compile all your completed tasks into a creative portfolio (in your activity file), including photograph, report, presentation etc. Write a brief reflection on what you enjoyed most about the assignment and how it enhanced your understanding and appreciation of mathematics.

SUBJECT-SCIENCE

CHEMISTRY-

- To prepare a project on the topic "Types of chemical reactions".
- Balance the following equations:
 - $\text{NH}_3 + \text{CuO} \rightarrow \text{Cu} + \text{N}_2 + \text{H}_2\text{O}$
 - $\text{Al}(\text{OH})_3 \rightarrow \text{Al}_2\text{O}_3 + \text{H}_2\text{O}$
 - $\text{Mg}(\text{OH})_2 + \text{HCl} \rightarrow \text{MgCl}_2 + \text{H}_2\text{O}$
 - $\text{AlCl}_3 + \text{NH}_4\text{OH} \rightarrow \text{Al}(\text{OH})_3 + \text{NH}_4\text{Cl}$
 - $\text{NH}_4\text{NO}_2 \rightarrow \text{N}_2 + \text{H}_2\text{O}$
 - $\text{PbS} + \text{H}_2\text{O}_2 \rightarrow \text{PbSO}_4 + \text{H}_2\text{O}$
 - $\text{CuSO}_4 + \text{NaOH} \rightarrow \text{Cu}(\text{OH})_2 + \text{Na}_2\text{SO}_4$
 - $\text{MnO}_2 + \text{HCl} \rightarrow \text{MnCl}_2 + \text{H}_2\text{O} + \text{Cl}_2$
- What type of chemical reactions take place when:
 - A magnesium wire is burnt in air.
 - Lime stone is heated.
 - Silver bromide is exposed to sunlight.
 - Electricity is passed through water.
 - Ammonia and hydrogen chloride is mixed.

PHYSICS-

- The resistance whose V-I graph is given below is

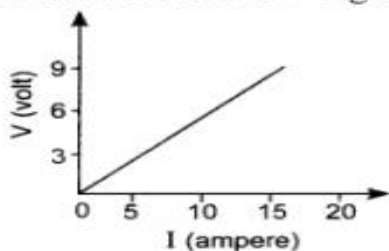

- | | |
|--------------------------|--------------------------|
| (a) $\frac{5}{3} \Omega$ | (b) $\frac{3}{5} \Omega$ |
| (c) $\frac{5}{2} \Omega$ | (d) $\frac{2}{5} \Omega$ |

- A wire of length l , made of material resistivity ρ is cut into two equal parts. The resistivity of the two parts are equal to,

- (a) ρ (b) $\frac{\rho}{2}$ (c) 2ρ (d) 4ρ

- A student carries out an experiment and plots the $I-V$ graph of three samples of nichrome wire with resistances R_1 , R_2 and R_3 respectively as shown in figure. Which of the following is true?

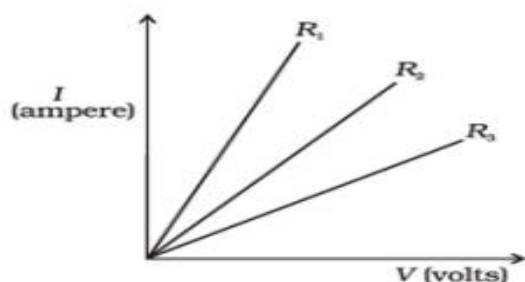

- | | |
|-----------------------|-----------------------|
| (a) $R_1 = R_2 = R_3$ | (b) $R_1 > R_2 > R_3$ |
| (c) $R_3 > R_2 > R_1$ | (d) $R_2 > R_3 > R_1$ |

- The resistivity does not change if

- | | |
|--|---|
| (a) the material is changed | (b) the temperature is changed |
| (c) the shape of the resistor is changed | (d) both material and temperature are changed |

5. Keeping the potential difference constant, the resistance of the circuit is halved. The current will become:

- (a) One-fourth (b) Four times (c) Half (d) Double

6. When a 40V battery is connected across an unknown resistor there is a current of 100 mA in the circuit. Find the value of the resistance of the resistor:

- (a) 4000Ω (b) 400Ω (c) 0.4Ω (d) 40Ω

7. Identify the circuit in which the electrical components have been properly connected.

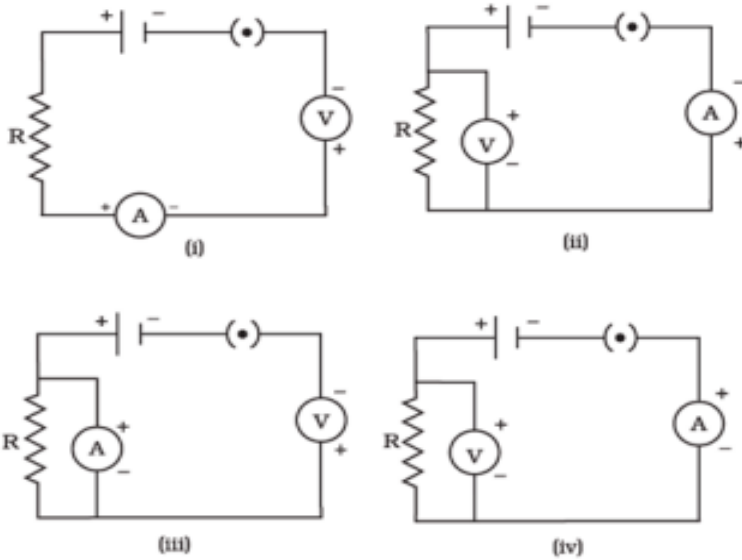

- (a) (i) (b) (ii) (c) (iii) (d) (iv)

8. A given length of a wire is doubled on itself and this process is repeated once again. By what factor does the resistance of the wire change?

- (a) $\frac{1}{4}$ (b) $\frac{1}{2}$ (c) $\frac{1}{8}$ (d) $\frac{1}{16}$

9. The figure below shows two copper wires X and Y of different length and same cross sectional area. Then



- (a) Resistance of wire X > Resistance of wire Y
 (b) Resistance of wire Y > Resistance of wire X
 (c) Resistance of wire X = Resistance of wire Y
 (d) None of these

10. The property of a substance which offers opposition to the flow of current through it is called

- (a) Energy (b) current (c) resistance (d) voltage

BIOLOGY-

Q 1- Prepare a working model of the heart showing its internal structure.

Q 2- Visit the doctor to learn the working of a sphygmomanometer to measure blood pressure and explain its functioning.

Q 3- Visit a pathology to see how a slide of blood smear is prepared to see blood cells and prepare a chart of cells.

Q 4- Prepare a diet chart showing different kinds of food items and amount of calories they provide. Also write the amount of calories required by a child, an adult and an old person as a balanced diet.

SUBJECT-SOCIAL SCIENCE

HISTORY & CIVICS-

Prepare a detailed project on **“MAKING OF A GLOBAL WORLD”**.

Subtopics to be highlighted in the project:

- 1- Implication of globalization for local economies
- 2- Globalisation is experienced differently by different social groups. How?
- 3- How the transportation works as a life line of economy

GEOGRAPHY-

Prepare an article on the following topic:

“TOURISM IN INDIA HAS GROWN AS AN INDUSTRY”

Instructions:

- *Firstly, search online sources to consult or gather information and data regarding the topic. Also take help from the NCERT Book: CONTEMPORARY INDIA-II*
- *Complete your article within 10 lined sheets.*
- *Use a folder made up of biodegradable material.*
- *Use some pictures, diagram, map etc.*
- *Use pencil colours and blue/black pen for any diagram or map.*
- Include following heads:
 - **TITLE PAGE**
 - **CONTENTS**
 - **ACKNOWLEDGEMENT**
 - **INTRODUCTION**
 - **TYPES OF TOURISM ACTIVITIES IN INDIA**
 - **ECOTOURISM FOR SUSTAINABLE ENVIRONMENT**
 - **ROLE OF TRANSPORTATION IN TOURISM DEVELOPMENT IN INDIA**
 - **FUTURE PROSPECTS IN TOURISM INDUSTRY**

ECONOMICS-

Prepare a project report of 5-6 pages on following topic:

“Global warming is the impact industrialization, urbanization and modernization”

Do some research work, quote some incidents/examples and support it with some pictures/posters/images/newspaper cuttings/articles/cartoons etc.

NOTE: Submit your project by July, 07, 2023

SUBJECT-COMPUTER

Practical File : Write coding of at least 10 HTML webpages and attach screenshot/printout of the same webpage.

SUBJECT-ART

Prepare a poster on topic "Preserve our Natural Resources".